

KIT-LIGHT 3 Beleuchtungs-Kit für BL-SMALL KIT-LIGHT 5 Kit luci per BL-SMALL KIT-LIGHT 5 Light bars kit for BL-SMALL

1 SCHRANKENBAUM VORBEREITEN • PREPARAZIONE DELLA BARRA • PREPARE THE ARM

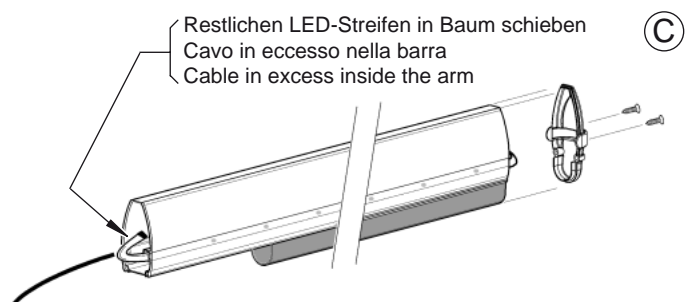

2 SCHRANKENBAUM MONTIEREN • INSTALLARE LA BARRA • INSTALL THE ARM

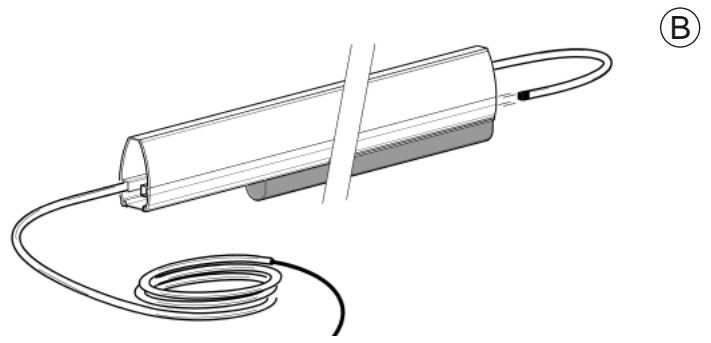
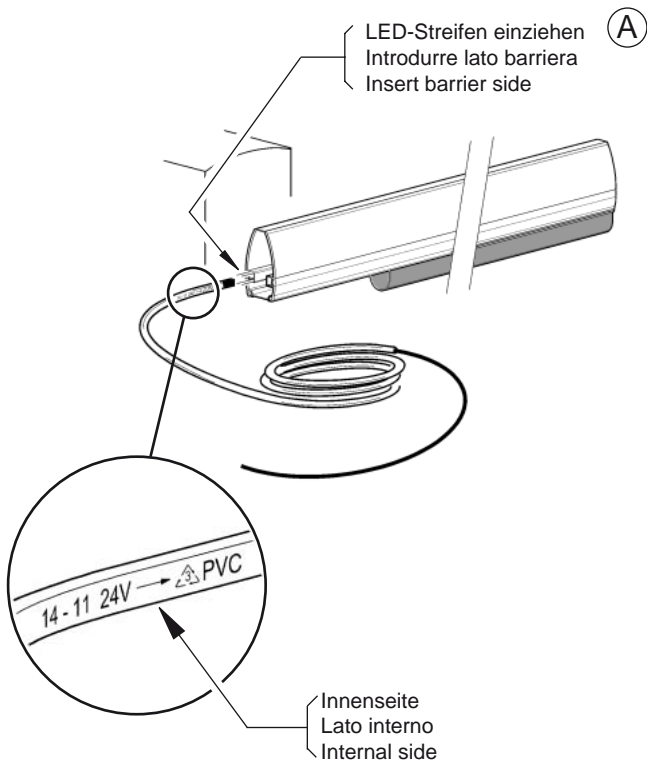
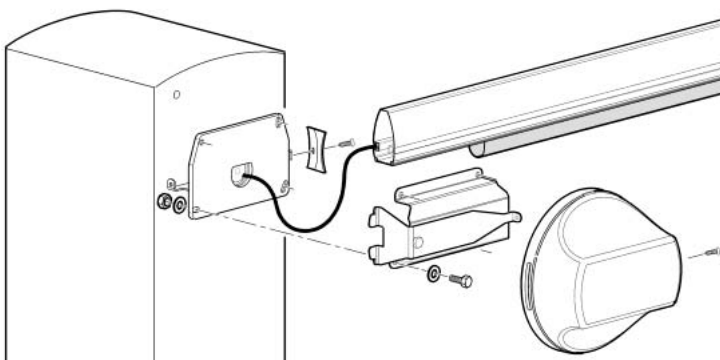
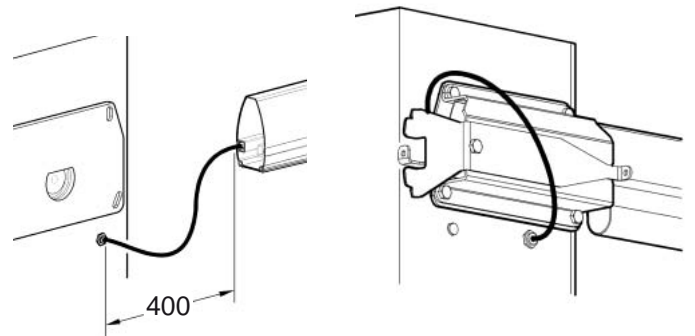
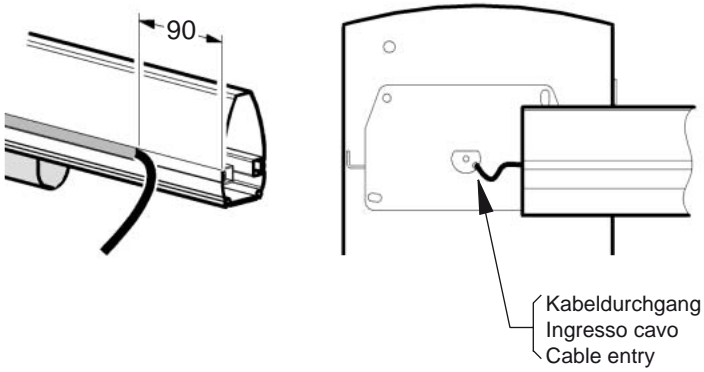

3

KABELFÜHRUNG IN DER SCHRANKE • POSIZIONARE IL CAVO NELLA BARRIERA • PLACING THE CABLE IN THE BARRIER

BAUM RECHTS
BARRA DESTRA
RIGHT ARM

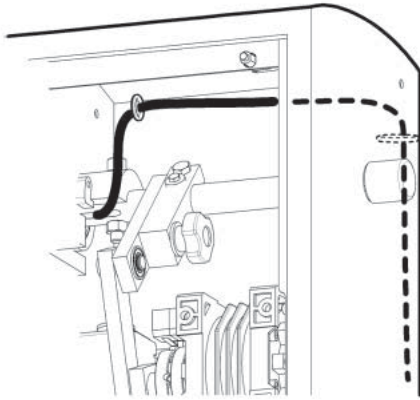

BAUM LINKS
BARRA SINISTRA
LEFT ARM

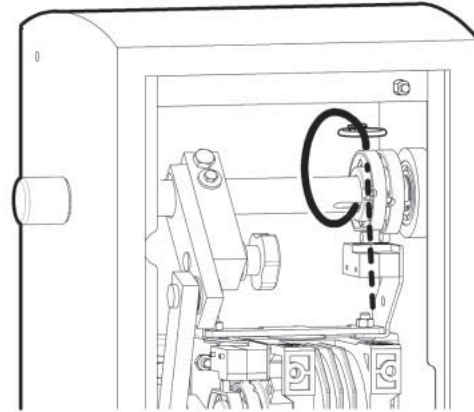

4

ELEKTRISCHER ANSCHLUSS • COLLEGAMENTI ELETTRICI • ELECTRICAL CONNECTIONS

B3000
B5000

SA24

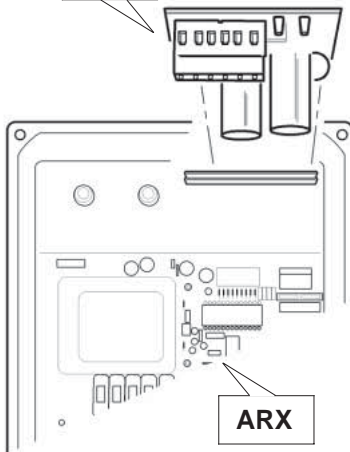

B24

SA24

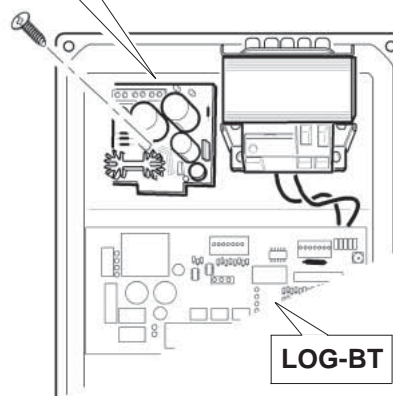

SA24

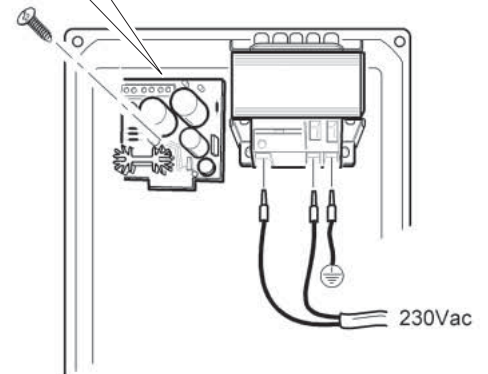

ARX

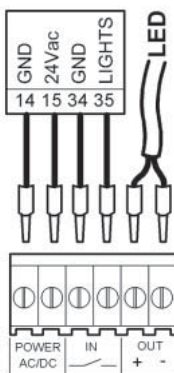

SA24

LOG-BT

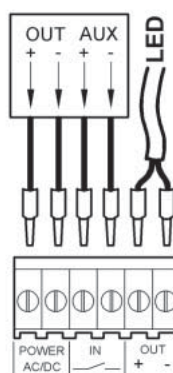

SA24

Leuchtet die LED-Streifen nicht, die Anschlussdrähte an out +/- tauschen

Nel caso le luci non si accendano invertire le connessioni out +/-

In case of light-off, invert the out +/- connection



- **WARNING!** Bei allen Arbeiten an der Anlage ist die Netzspannung zu abzuschalten.
- **PERICOLO!** Prima di effettuare qualsiasi intervento sull'impianto togliere l'alimentazione elettrica.
- **DANGER!** Always disconnect the electricity before attempting any work on the system.